



Matte Black (Finish ID:19)

ROCHER BACK TO BACK

	Item Code	Size (mm & Inches)	Material	Size (Inches)				Fig.
				A	B	C	D	
1	DDP.604.12".XX.XXX.XXXX	304.8mm (12")	Brass	18	0.98	12	2.24	1
2	DDP.604.18".XX.XXX.XXXX	457.2mm (18")	Brass	24	0.98	18	2.24	1
3	DDP.604.24".XX.XXX.XXXX	609.6mm (24")	Brass	30	0.98	24	2.24	1
4	DDP.604.30".XX.XXX.XXXX	762mm (30")	Brass	36	0.98	30	2.24	1
5	DDP.604.12".XX.XXX.XXXX	304.8mm (12")	Hammered over Brass	18	0.98	12	2.24	1
6	DDP.604.18".XX.XXX.XXXX	457.2mm (18")	Hammered over Brass	24	0.98	18	2.24	1
7	DDP.604.24".XX.XXX.XXXX	609.6mm (24")	Hammered over Brass	30	0.98	24	2.24	1
8	DDP.604.30".XX.XXX.XXXX	762mm (30")	Hammered over Brass	36	0.98	30	2.24	1

"XX" in item code denotes Finish ID.
 "XXX" in item code denotes Door Thickness.
 "XXXX" in item code denotes Door Material.

This product is Supplied with Mounting Kit including with the Order.

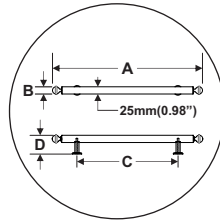

FIG. 1

How to Order

DDP.604.12".19.WOOD.1 3/4"



Rocher Back To Back Door Pull Finish Options

Base Material : Brass			Standard Finishes (2-3 Weeks Delivery)			
						
Bright Chrome (Finish ID:2)	Brush Nickel (Finish ID:3)	Aged Brass (Finish ID:4)	Unlacquered Polished Brass (Finish ID:7U)	Polished Nickel (Finish ID:8)	Satin Brass (Finish ID:13)	
Base Material : Brass			Custom Finishes (3-4 Weeks Delivery)*			
						
Lacquered Polished Brass (Finish ID:7L)	Hammered over Brush Nickel (Finish ID:12-3)	Hammered over Aged Brass (Finish ID:12-4)	Hammered over Polished Nickel (Finish ID:12-8)	Hammered over Satin Brass (Finish ID:12-13)	Matte Black (Finish ID:19)	Split Black and Polished Nickel (Finish ID:48)
						
Graphite (Finish ID:61)	Split Brush Nickel and Satin Brass (Finish ID:78)	Split Graphite and Satin Brass (Finish ID:90)	Split Graphite and Brush Chrome (Finish ID:91)	Ombre (Finish ID:92)	Brush Chrome (Finish ID:95)	

Door Material	Door Thickness
1. Wood	5/16", 3/8", 1/2", 3/4", 1", 1 1/4", 1 1/2", 1 3/4", 2", 2 1/4", 2 1/2"
2. Metal	5/16", 3/8", 1/2", 3/4", 1", 1 1/4", 1 1/2", 1 3/4", 2", 2 1/4", 2 1/2"
3. Glass	5/16", 3/8", 1/2", 3/4", 1"

- Custom finishes cannot be returned or refunded. We are unable to accept cancellations for custom finish order unless within 48 hours of the order being placed.
- We have uniform pricing for all non-hammered finishes listed above as long as base material and size is same.
- Contact us for customized finishes, refer pages F1, F2, F3 & F4 for finish glossary.

Rocher Back To Back Door Pull Split Finish

DDP.604.XX.XX

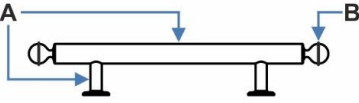
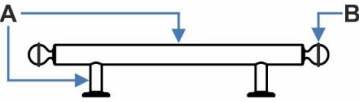
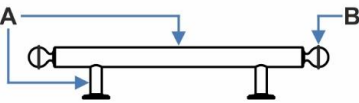
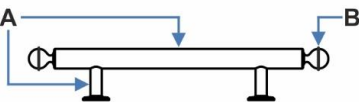
FINISH CODE (XX)	FINISH NAME	LINE DRAWING	A	B
DDP.604.XX.48	Split Black and Polished Nickel		Matte Black	Polished Nickel
DDP.604.XX.78	Split Brush Nickel and Satin Brass		Brush Nickel	Satin Brass
DDP.604.XX.90	Split Graphite and Satin Brass		Graphite	Satin Brass
DDP.604.XX.91	Split Graphite and Brush Chrome		Graphite	Brush Chrome

**BACK TO BACK
HANDLE ILLUSTRATED**

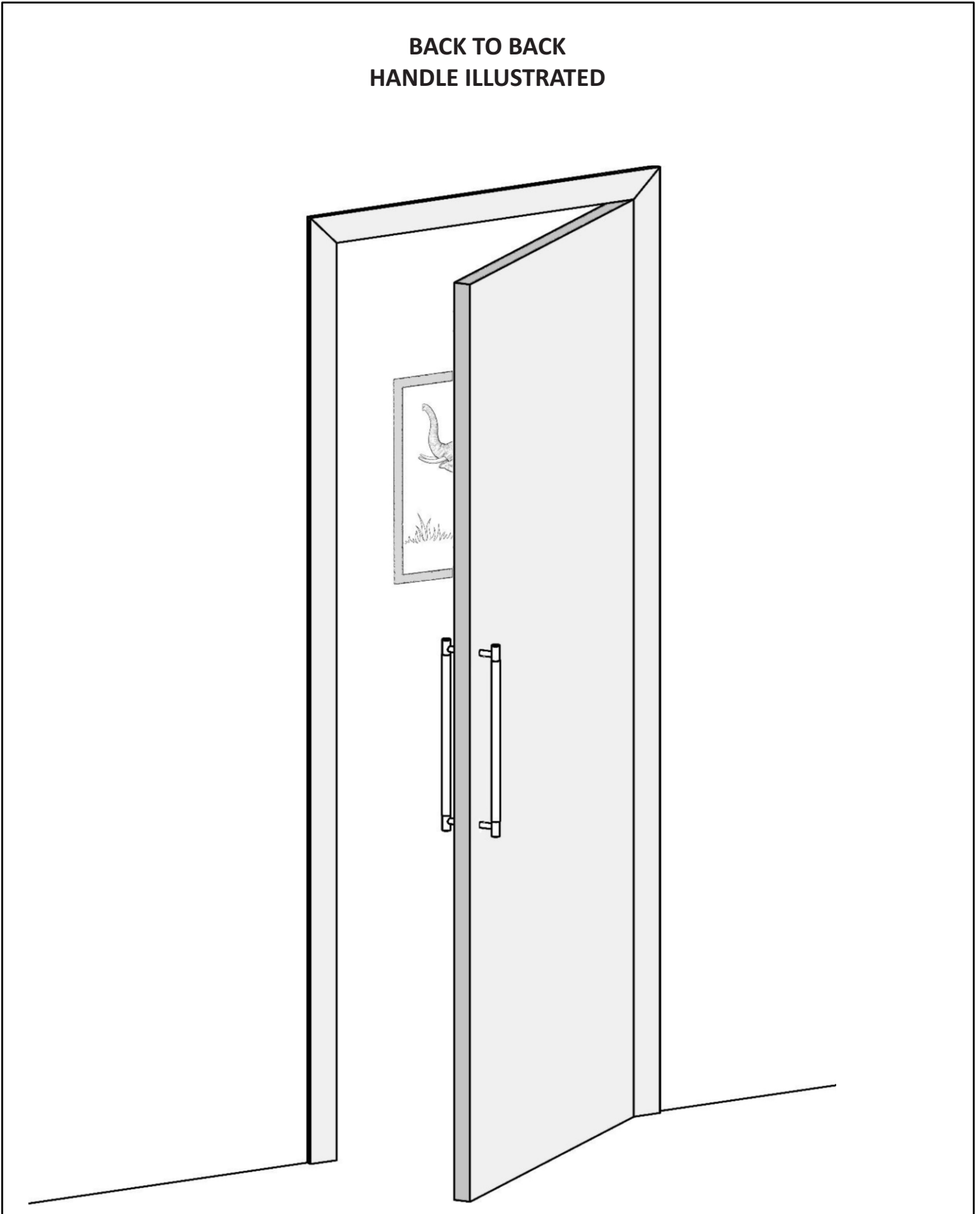

Required Tools

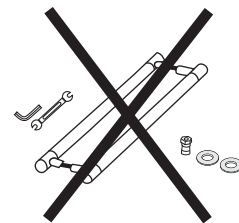
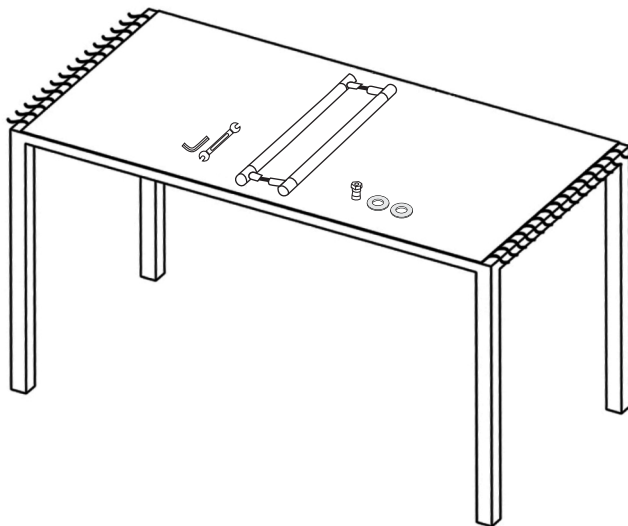
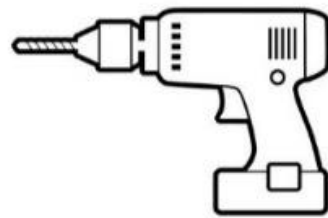
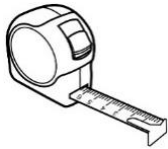

Step Wise Packing List			
S.No.	Part Number	Qty	Steps
1	DDP.604.XX.XX.XXX.XXXX	1x	1
2	SLEEVE	1x	1
3	LNKY2.5	1x	1
4	INSERT	1x	1
5	WASHER	2x	1
6	DDP.SPANNER (No.10,11)	1x	4
7	Manual	1x	-

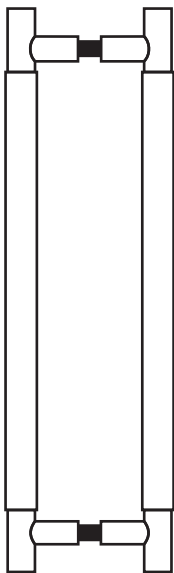
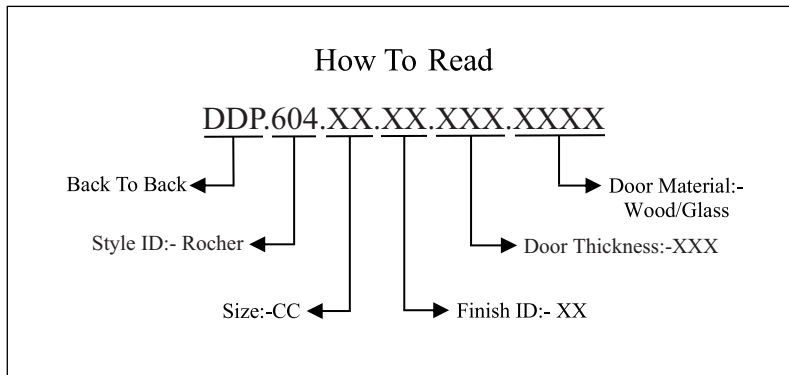

DDP.604.XX.XX.XXX.XXXX



LNKY2.5



INSERT

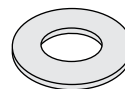

WASHER

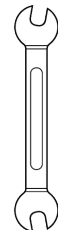

DDP.SPANNER (No.10,11)



STEP-1

Step Wise Packing List			
S.No.	Part Number	Qty	Steps
1	DDP.604.XX.XX.XXX.XXXX	1x	1
2	SLEEVE	1x	1
3	LNKY2.5	1x	1
4	INSERT	1x	1
5	WASHER	2x	1

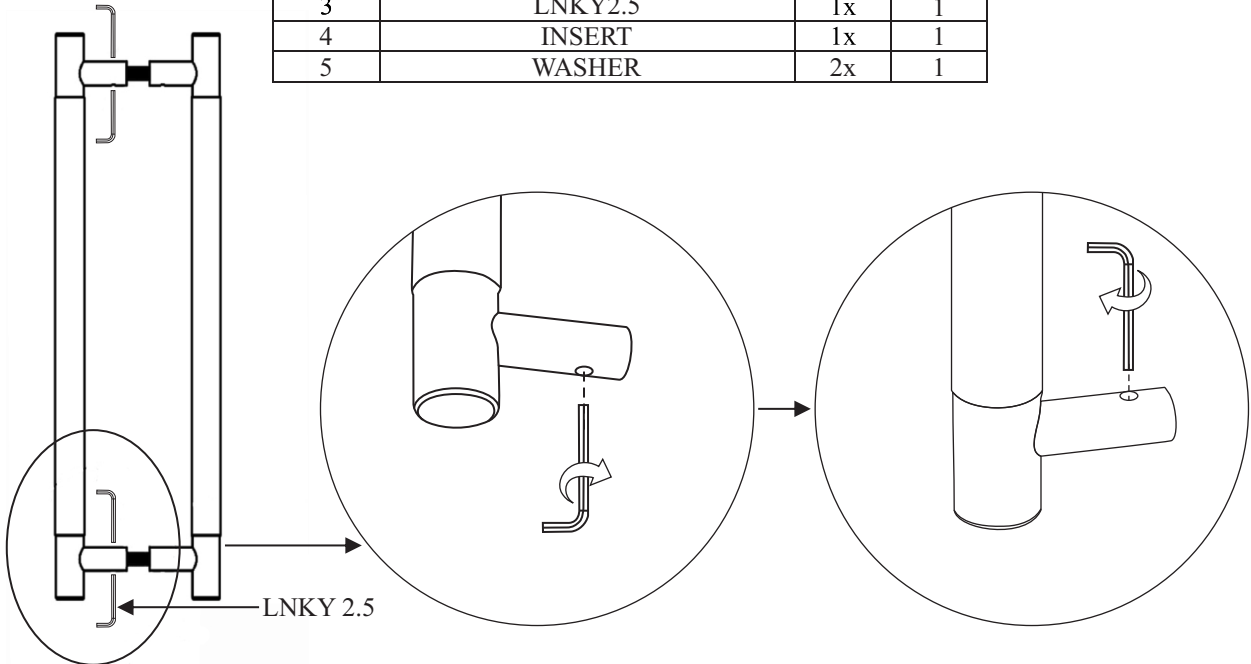

DDP.604.XX.XX.XXX.XXXX

Including only
Glass Door
use Sleeve

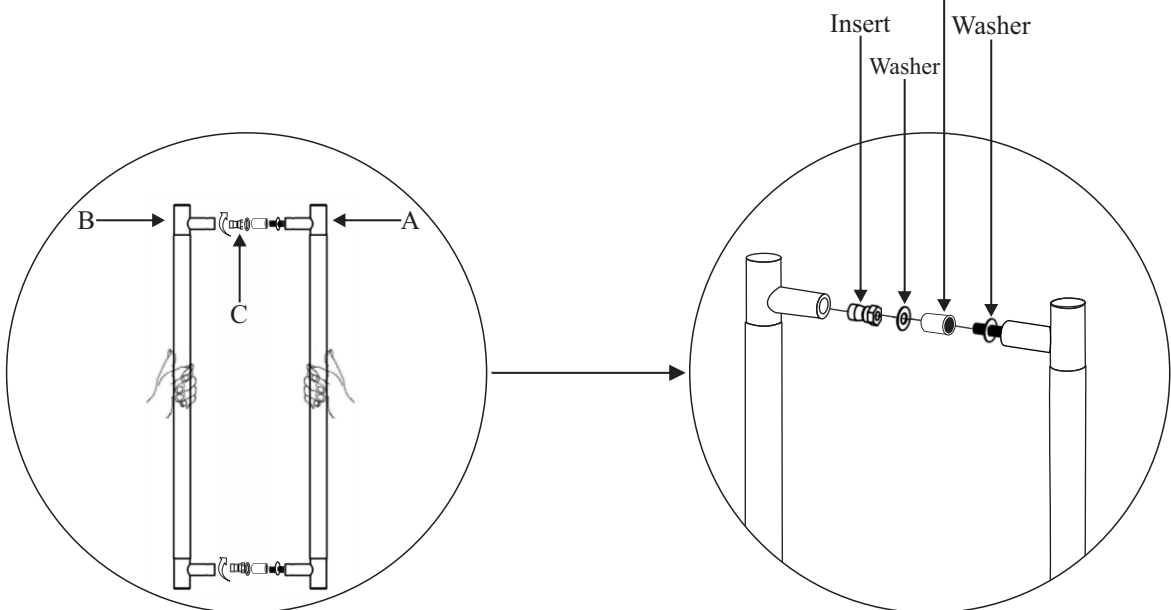

STEP-2

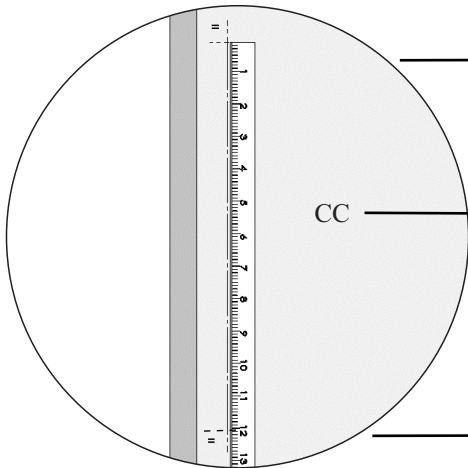
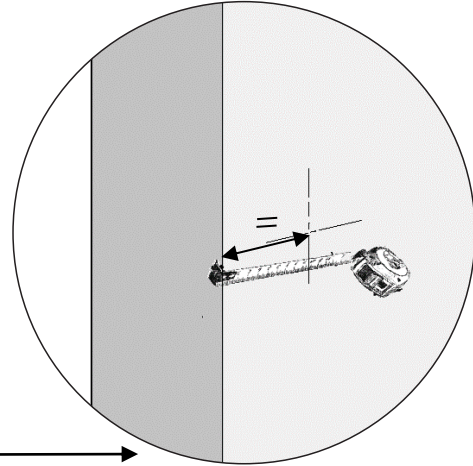
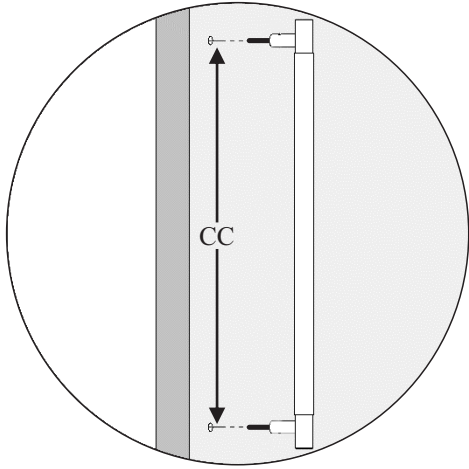

DDP.604.XX.XX.XXX.XXXX

Size:-CC
12"
18"
24"
30"

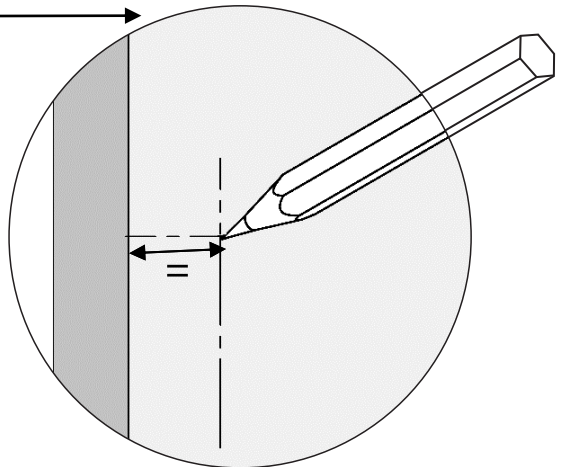
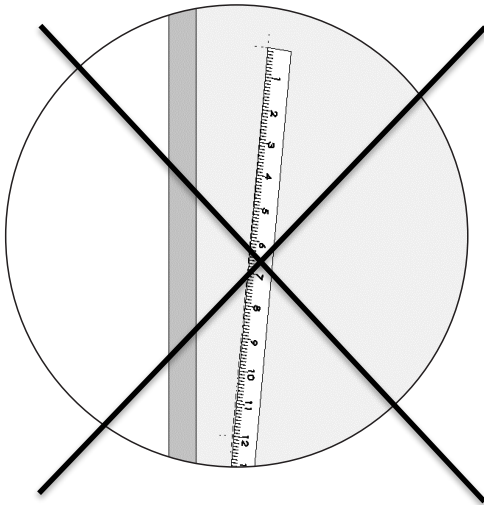

STEP-3

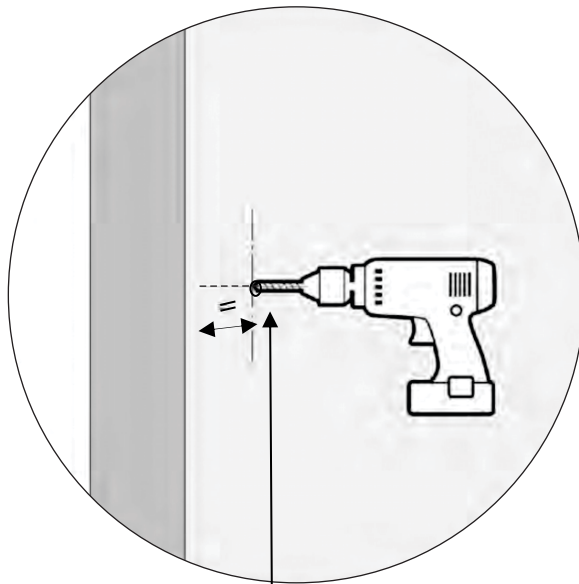
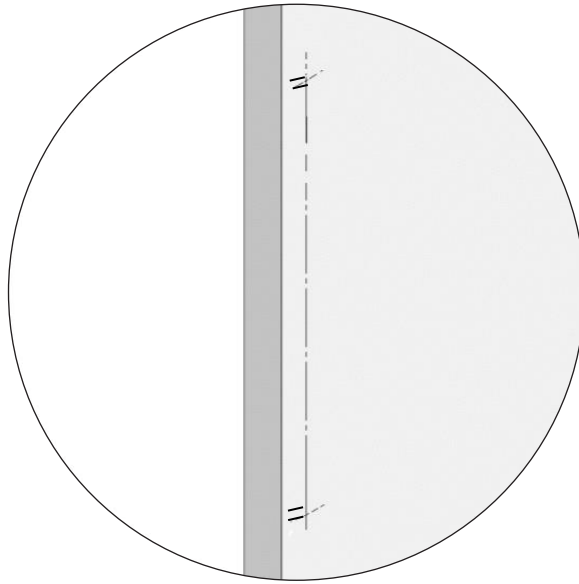

DRILL SIZE			
	Glass	Wood	Metal
DDP	3/8" (9.5mm)	1/4" (6.4mm)	1/4" (6.4mm)

STEP-4

Step Wise Packing List			
S.No.	Part Number	Qty	Steps
6	DDP.SPANNER (No.10,11)	1x	4

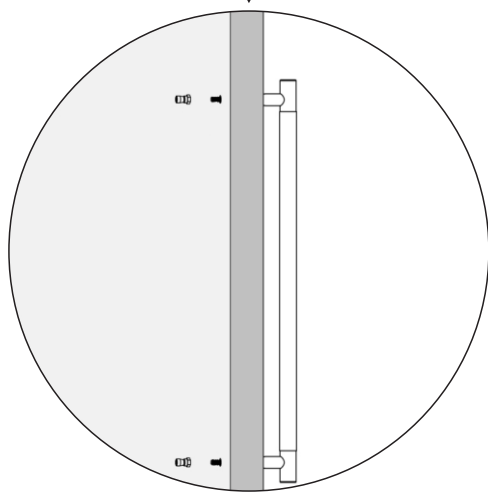
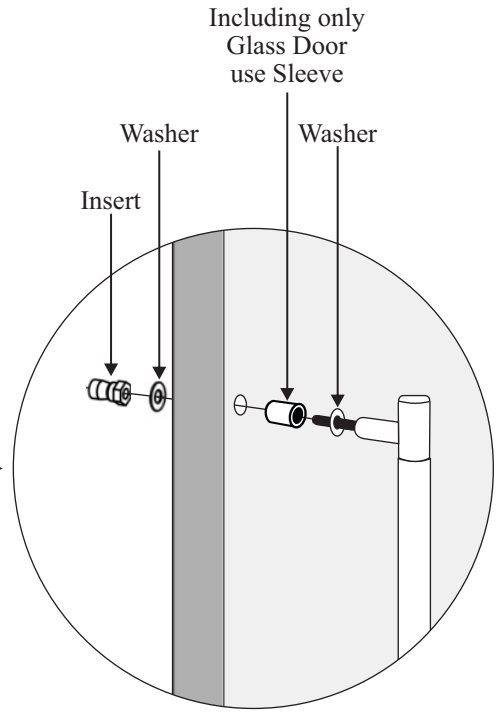
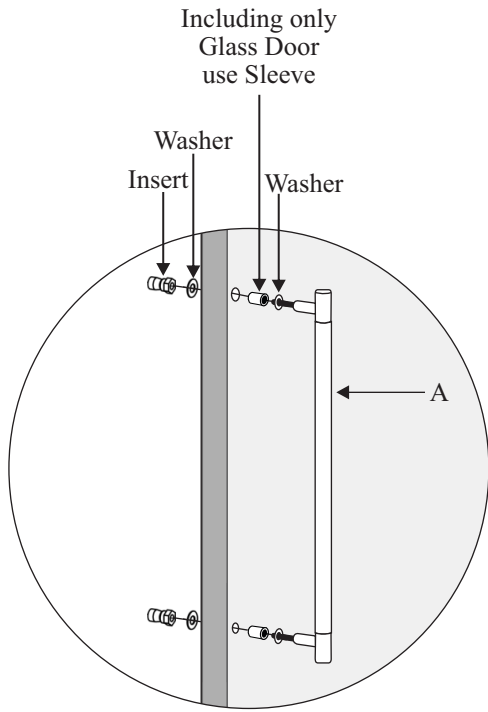
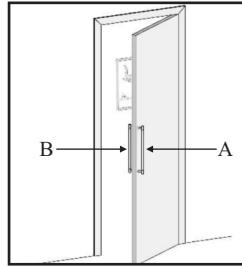

DDP.SPANNER (No.10,11)

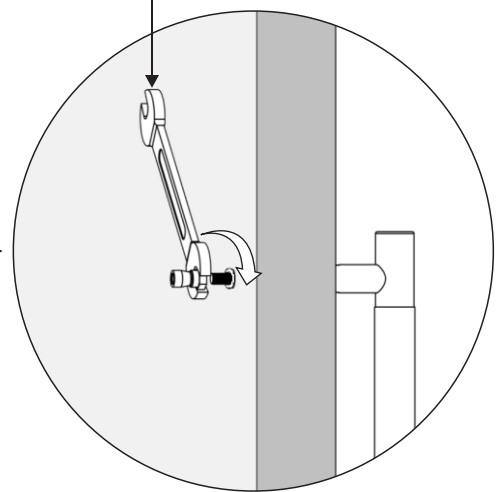

STEP-5

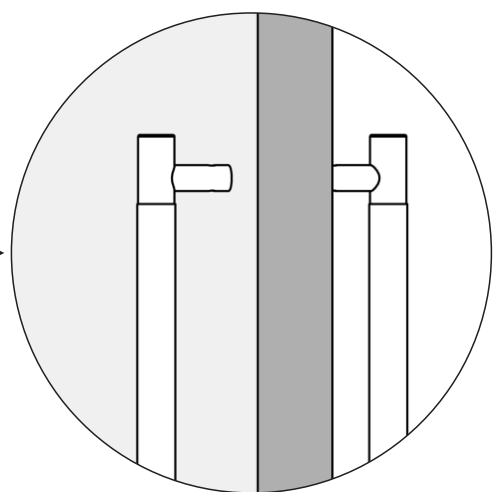
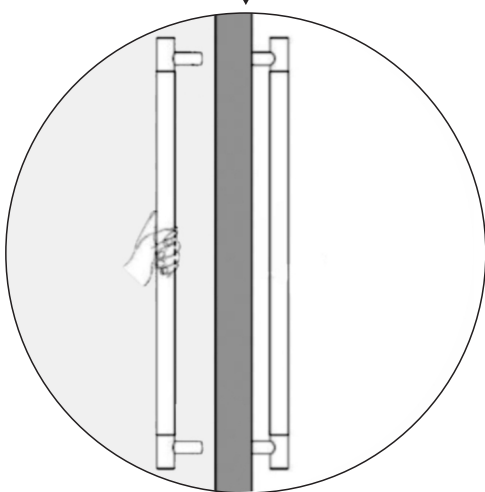
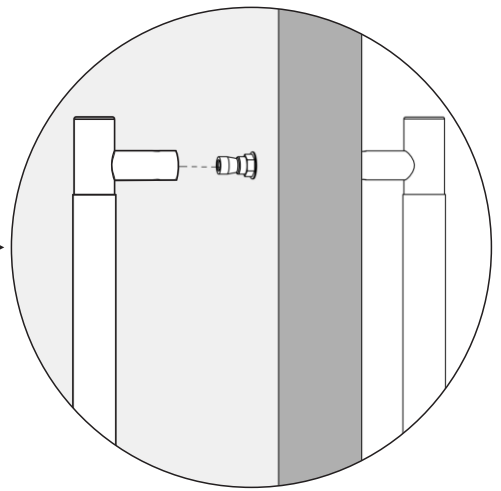
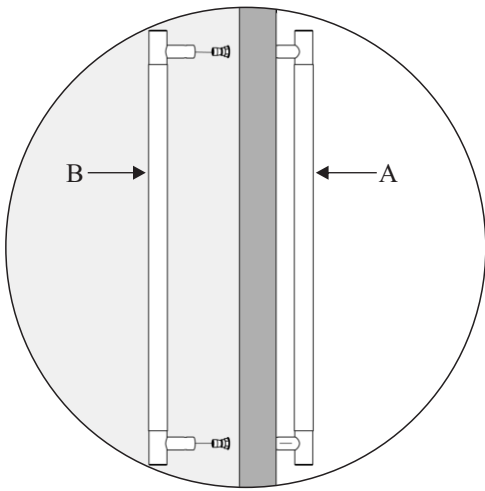
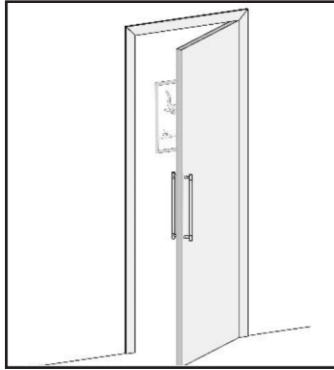

STEP-6

